

IQAN-LC6-X05

Instruction book

Publ no MSG17-8409-IB/UK
Edition 2018-09-05

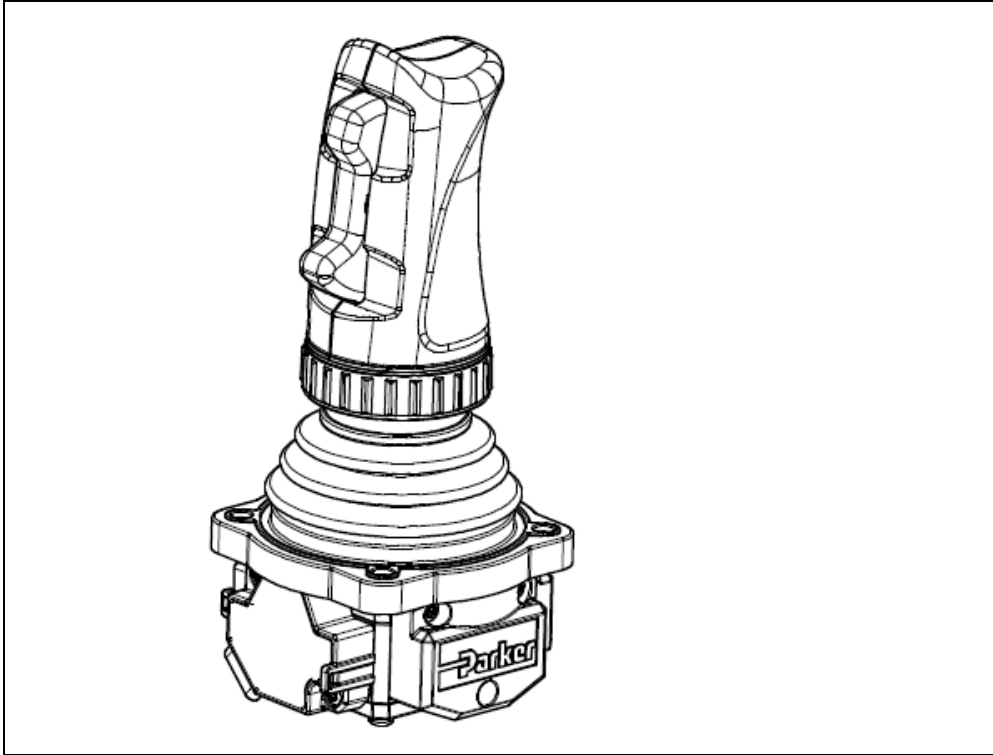

Contents

1	Introduction	1
	Safety symbols	1
2	Precautions	2
	General safety regulations	2
	Construction regulations	2
	Safety during installation	2
	Safety during start-up	3
	Safety during maintenance and fault diagnosis	3
3	Product description	4
	IQAN-LC6-X05	4
	The control lever's parts	4
	The IQAN-LC6-X05 control signals	5
	I/O overview, base	5
	H1-handle	6
	The handle's parts	6
	I/O overview, H1 handle	7
	Outputs	7
	Markings/Approvals	8
4	Safety	9
	IQAN-LC6-X05	9
	Primary and secondary signals	9
	Use of limited signal range	9
	EN 13849-1	9
5	Mounting	10
	Mounting the unit	10
	Mounting considerations	10
	Mounting methods	11
6	Installation	12
	IQAN-LC6-X05 Base connector	12
	Base connector pin assignments	12
	IQAN-LC6-X05 Handle connector	13
	H1-Handle connector pin assignments	13
	Supply voltage	14
	Emergency stop	14
	Connecting of supply voltage, IQAN module	14
	Output signals	15
	Primary and secondary outputs	15
	Connecting of IQAN-LC6-X05 base outputs	15
	Connecting of -H1 handle outputs	16
	LC6-H1 handle loss of ground	16
	Handle considerations	17
	Recommended handle specification	17
	Environmental specification	17
	Appendix A	18
	IQAN-LC6-X05 Technical Overview	18
	IQAN-LC6-X05, base and -H1 handle	18
	Appendix B	22
	Dimensioning of the IQAN-LC6-X05	22

1 Introduction

These instructions are to be used as a reference tool for the vehicle manufacturer's design, production, and service personnel.

The user of these instructions should have basic knowledge in the handling of electronic equipment.

Safety symbols

Sections regarding safety, marked with a symbol in the left margin, must be read and understood by everyone using the system, carrying out service work or making changes to hardware and software.

The different safety levels used in this manual are defined below.



WARNING

Sections labeled *WARNING* with a caution symbol in the left margin, indicate that a hazardous situation exists. If precautions are not taken, this could result in death, injury, or property damage.



NOTICE

Sections labeled *NOTICE* with a notice symbol in the left margin, indicate there is important information about the product. Ignoring this could result in less than optimal performance, or damage to the product.

Contact the manufacturer if there is anything you are not sure about or if you have any questions regarding the product and its handling or maintenance.

The term "manufacturer" refers to Parker Hannifin Corporation.

2 Precautions

General safety regulations

Work on the hydraulics control electronics may only be carried out by trained personnel who are well-acquainted with the control system, the machine and its safety regulations.



WARNING

Mounting, modification, repair and maintenance must be carried out in accordance with the manufacturer's regulations. The manufacturer has no responsibility for any accidents caused by incorrectly mounted or incorrectly maintained equipment. The manufacturer does not assume any responsibility for the system being incorrectly applied, or the system being programmed in a manner that jeopardizes safety.



WARNING

Damaged product may not be used. If the control system shows error functions or if electronic modules, cabling or connectors are damaged, the system shall not be used.



WARNING

Electronic control systems in an inappropriate installation and in combination with strong electromagnetic interference fields can, in extreme cases, cause an unintentional change of speed of the output function.



NOTICE

As much as possible of the welding work on the chassis should be done before the installation of the system. If welding has to be done afterwards, the electrical connections on the system must be disconnected from other equipment. The negative cable must always be disconnected from the battery before disconnecting the positive cable. The ground wire of the welder shall be positioned as close as possible to the place of the welding. The cables on the welding unit shall never be placed near the electrical wires of the control system.

Construction regulations



WARNING

The vehicle must be equipped with an emergency stop which disconnects the supply voltage to the control system's electrical units. The emergency stop must be easily accessible to the operator. The machine must be built if possible, so that the supply voltage to the control system's electrical units is disconnected when the operator leaves the operator's station.

Safety during installation



WARNING

Incorrectly positioned or mounted cabling can be influenced by radio signals which can interfere with the functions of the system.

Safety during start-up



WARNING

The machine's engine must not be started before the control system is mounted and its electrical functions have been verified.

Ensure that no one is in front, behind or nearby the machine when first starting up the machine.

Follow the instructions for function control in the Start-up section.

Safety during maintenance and fault diagnosis



WARNING

Ensure that the following requirements are fulfilled before any work is carried out on the hydraulics control electronics.

- The machine cannot start moving.
- Functions are positioned safely.
- The machine is turned off.
- The hydraulic system is relieved from any pressure.
- Supply voltage to the control electronics is disconnected.

3 Product description

IQAN-LC6-X05

The IQAN-LC6-X05 is a mini-coordinate joystick that incorporates ergonomic design with ruggedness, functionality, light weight and high flexibility for mobile market applications. The unit is designed for withstand aggressive conditions in different type of mobile equipment. The LC6 has a compact ergonomic design and small dimensions make it ideal for armrest and panel mounting. The designation -X05 (**X** crossed outputs, **0 - 5 Vdc**) represents the analog output signals. The joystick has one primary and one secondary output per axis in the 0-5V range

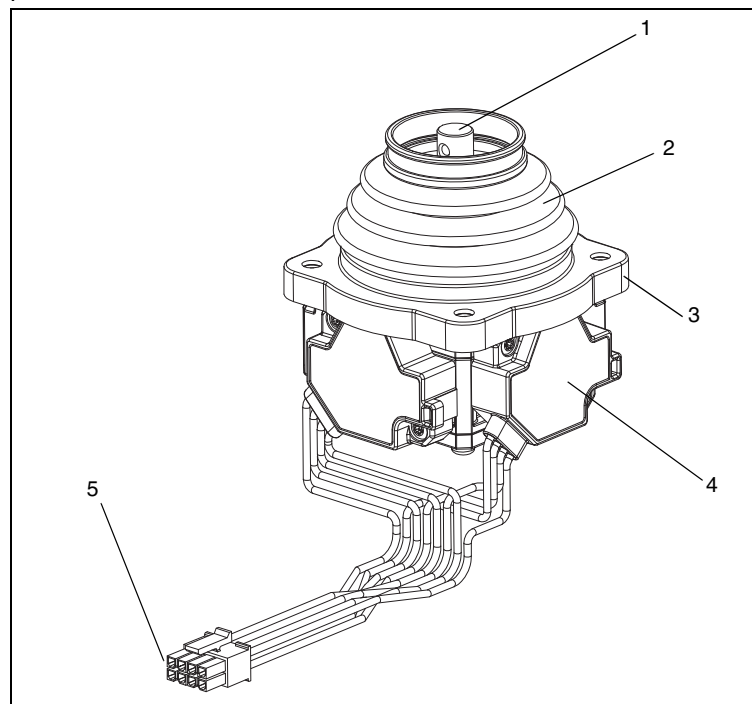

The IQAN-LC6-X05 parts.

The control lever's parts

Control lever -LC6-X05 consists of:

- 1 U0-handle.
- 2 Bellows.
- 3 Mounting flange.
- 4 Lower enclosure.
- 5 Connector C1 for supply voltage, primary and secondary analog outputs



NOTICE

In order to increase the safety of the LC6-X05, the primary (10%-90% V_S) and secondary (90%-10% V_S) analog outputs can be compared e.g. to verify center position. See safety chapter for more information.

The IQAN-LC6-X05 control signals

The IQAN-LC6 is used to control the object in four directions:

- the lever is moved to the right/left, direction X +/-.
- the lever is moved forward/back, direction Y +/-.
- handle option -H1R1, the rocker is moved up/down, direction Z1 +/-.
- handle option -H1R1K1, the ring is moved right/left, direction Z2 +/-.

The control signal is proportional to the lever's working range.

The control signal is transferred from the IQAN-LC6-X05 via a cable to the valve driver electronics, an expansion module, or IQAN master unit.

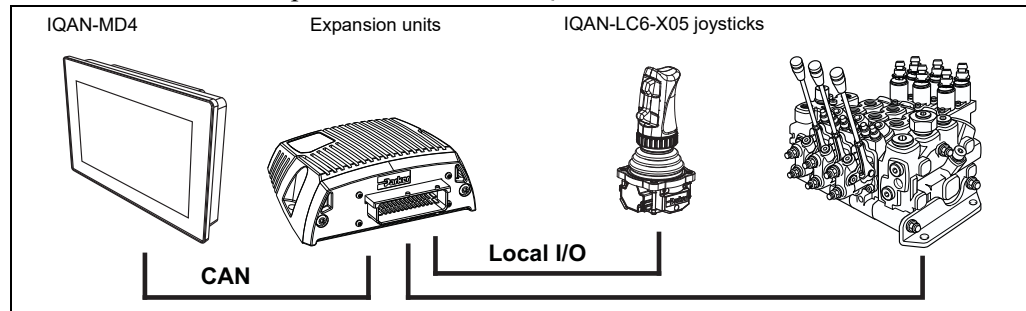

IQAN-LC6-X05 in a typical system

I/O overview, base

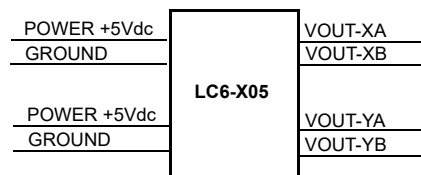

Outputs

The IQAN-LC6-X05 joystick base has four (4) *analog outputs* for use as command signals.

(2) Primary analog outputs VOUT-XA and VOUT-YA, 10% - 90% Vs

(2) Secondary analog outputs VOUT-XB and VOUT-YB, 90% - 10% Vs

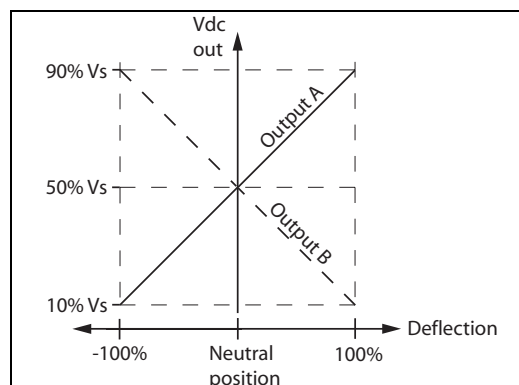

IQAN-LC6-X05 outputs per axis.

H1-handle

The IQAN-LC6-X05 is designed to be used with the ergonomic (H1) handle. The H1 handle has a connector C2 that is separate from the base connector.

The ergonomic handle has a 3rd proportional function rocker and a unique, patent pending, rotary knob function that adds a fourth proportional function integrated in the handle. The design gives the user a benefit to control all joystick proportional functions without changing their grip on the handle, and makes the LC6 ideal for repetitive, precise motion control during extended periods in mobile applications.

To extend operating life the housing of both handle and base is made of a corrosive-free material, and is specially adapted for moisture drainage to protect the the system electronics. The H1 handle uses a bellow that can be quickly changed without removing the handle to simplify field replacement. The cable between base and handle is routed directly through the base plate, eliminating the risk of damage and simplifying field service, while the use of a single circuit board and Hall effect sensors minimise the number of components and moving parts.



WARNING

If handle is disassembled there is a risk of pinching the cables when the handle is reassembled.

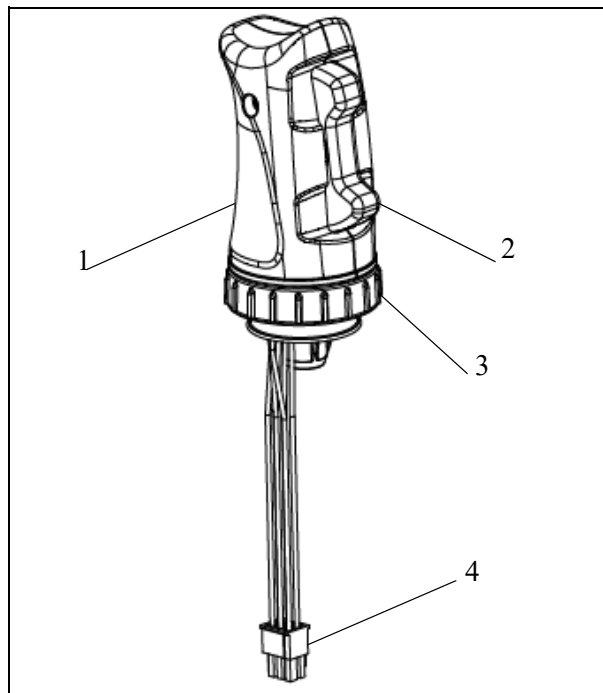

The IQAN-LC6-X05 H1 handle parts.

The handle's parts

H1 handle consists of:

- 1 Handle, -H1-R1K1 shown, (other configurations are possible).
- 2 Proportional rocker, (-H1 handle rocker has primary and secondary outputs).
- 3 Proportional knob (-H1 handle knob has primary and secondary outputs).
- 4 Connector C2 for supply voltage, primary and secondary analog outputs

I/O overview, H1 handle

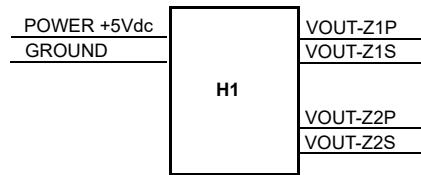

Outputs

Analog

The IQAN-LC6-X05 H1 handle has two(2) or four (4) analog outputs from knob and/or rocker, for use as command signals.

(2) Primary analog outputs VOUT-Z1P and VOUT-Z2P, 10%-90% Vs

(2) Secondary analog outputs VOUT-Z1S and VOUT-Z2S, 90% - 10% Vs

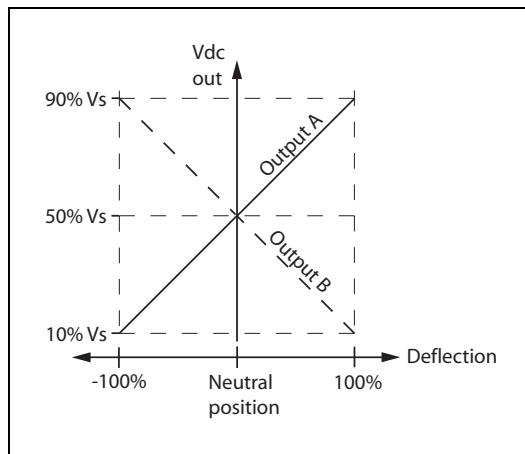

H1 handle outputs per Z axis.

Markings/Approvals

The markings/approvals reflect the state of the products at the time of publishing.



Declaration of Conformity

We: Parker Hannifin Manufacturing Sweden AB
Mobile Hydraulic Systems Division

Located at: Mölnlycke Fabriker 14
S-435 35 Mölnlycke, SWEDEN
Tel. +46 31 750 44 00

Declare that the products identified herein comply with the essential requirements of the following EU directives:

2014/30/EU **EU EMC Directive**
2011/65/EU **EU RoHS II Directive**

Harmonized standards:

ISO 14982:2009 Agricultural and forestry machines - Electromagnetic compatibility - Test methods and acceptance criteria
EN 13309:2010 Construction machinery - Electromagnetic compatibility of machines with internal electrical power supply
EN 50581:2012 Technical documentation for the assessment of electrical and electronic products with respect to the restriction of hazardous substances

Trade Name: Electrohydraulic Control Systems

Products: **IQAN-LC6**

Signature of responsible party: 

Printed name of responsible party: Håkan Jisland
Position of responsible party: Business Unit Manager

Executed on August 21th 2018, at Mölnlycke, Sweden

4 Safety

IQAN-LC6-X05

Primary and secondary signals

The IQAN-LC6-X05 has two signals outputs for each axis. The signals are antivalent, meaning that the secondary output when correct will be the "mirror image" of the primary signal. It is recommended to compare the signals in the controller to detect fault and protect against unwanted movement.

Use of limited signal range

The analog outputs of the IQAN-LC6-X05 use limited signal range to provide an additional method for error detection. The operating signal range for primary and secondary outputs are 10%-90% Vs and 90%-10% Vs respectively. Vs (power supply) is 5Vdc. This allows the controller to detect if a wire is pulled loose or making contact with a powered wire. Detecting wiring faults can protect against unintended movement.

EN 13849-1

MTTFd values specified in Appendix A are calculated based on FMEDA, for additional details on failure mode effect and failure mode distribution, please contact Parker.



WARNING

Risk of injury! Do not use in areas with high magnetic fields.

The IQAN-LC6-X05 is based on hall effect sensors. The LC6 is designed with magnetic deflection to reduce the influence of external magnetic fields, but exposure to high external magnetic fields may lead to unwanted activation of the output signals.

For maximum allowed external magnetic field, see Appendix A, on page 18.

5 Mounting

Mounting the unit



NOTICE

The IQAN-LC6-X05 unit should be mounted according to the following instructions.

Mounting considerations

- The control lever must be built in so that it is protected against direct pressurized liquid spray (above flange) and excessive mechanical forces.
- The machine manufacturer must consider the need of a protective catch, or similar, to prevent unintentional working of the lever.



NOTICE

Take careful consideration when positioning the unit.

- Mount the unit so that it is not exposed to external heat, e.g. from the engine or heater.
- Mount the unit so there is no risk that the harness can be folded, crushed, worn or damaged in any way.
- Locate the harness so there is no pressure on the connector.
- Use ergonomics. The control lever should be mounted at a height so that there is no pressure on the driver's arm and shoulders. IQAN-LC6 should be mounted at an angle so that the driver's wrist is held normally. The IQAN-LC6-X05 and a well designed handle, such as the H1, combined with moveable arm rests, can provide good ergonomics.

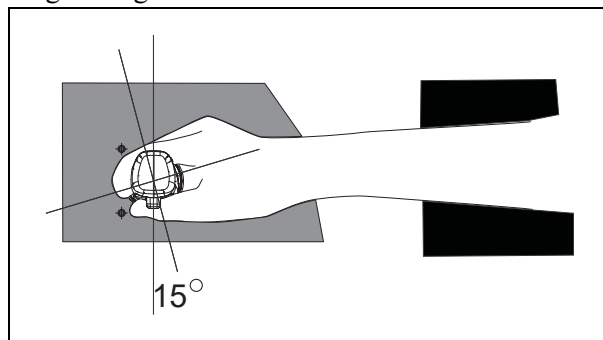

Ergonomic positioning of joystick

- The control lever IQAN-LC6-X05 with 3rd axis is intended to be positioned so that the rocker is manoeuvred with the thumb.

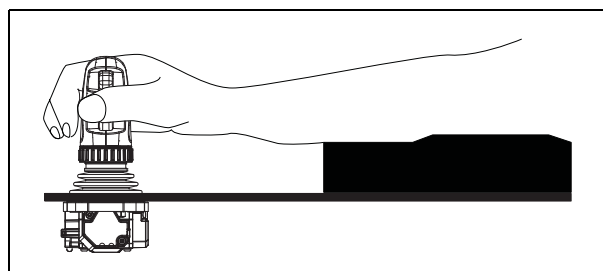

Actuating proportional rocker with thumb.

Mounting methods

- Control lever IQAN-LC6-X05 must only be mounted using screws through the flange.

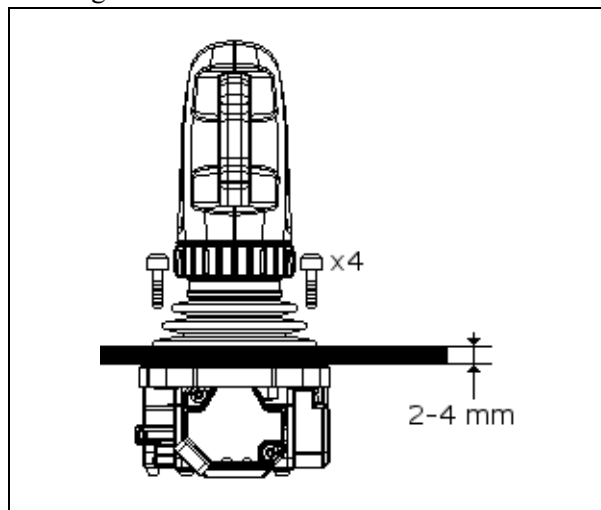

Mounting the IQAN-LC6-X05 with screws.

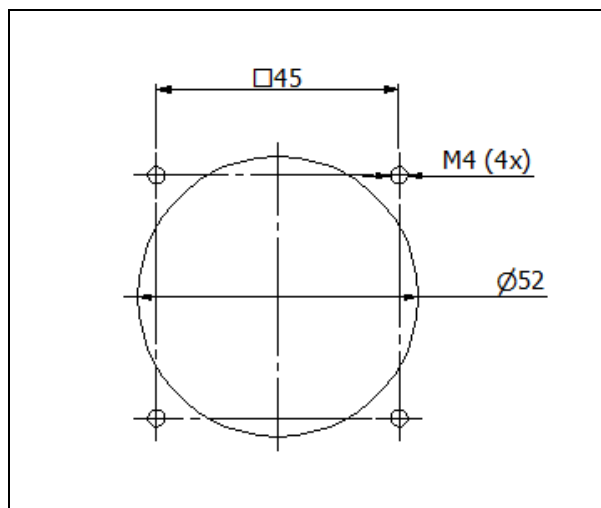

Mounting hole dimensions for the IQAN-LC6-X05.

6 Installation

IQAN-LC6-X05 Base connector

Connector kit	Parker no. 20077764^a	C1
Housing	Molex no. 43020-0801	
Pin type	Molex no. 43031-0008	
Recommended cable	0.50 mm ² (20 AWG)	
Crimping tool	Molex no. 63819-0000 or Molex no. 64016-0201	
Prototype cable	Parker no. 20077763^a	

a.Kit contains parts for both connectors, C1 and C2

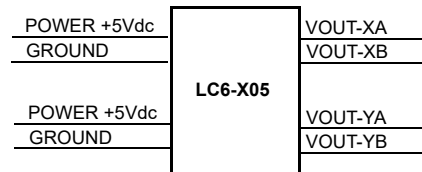

Base connector pin assignments

Symbol	Pin No.	Function
Power	5	X sensor power supply Vs, +5Vdc
GND	1	X sensor power supply ground , 0Vdc
Power	7	Y sensor power supply Vs, +5Vdc
GND	3	Y sensor power supply ground , 0Vdc
VOUT-XA	2	X primary signal
VOUT-XB	6	X secondary signal
VOUT-YA	4	Y primary signal
VOUT-YB	8	Y secondary signal

IQAN-LC6-X05 Handle connector

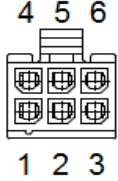
Connector kit	Parker no. 20077764^a	C2
Housing	Molex no. 43020-0601	
Pin type	Molex no. 43031-0008	
Recommended cable	0.50 mm ² (20 AWG)	
Supplied on handle types	H1-R1K0, H1-R1K1	
Prototype cable	Parker no. 20077763^a	

a.Kit contains parts for both connectors, C1 and C2

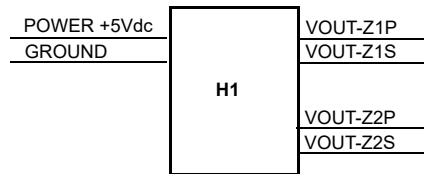

H1-Handle connector pin assignments

	H1-R1K0		H1-R1K1
Symbol	Pin No.		Pin No.
Power	4		4
GND	1		1
VOUT-Z1P	2		2
VOUT-Z1S	5		5
VOUT-Z2P			3
VOUT-Z2S			6

Supply voltage



WARNING

Before any installation of an IQAN system can take place, make sure the ignition lock is turned off and the battery is disconnected.

Emergency stop

Make sure an *Emergency Stop* disconnecting the system power supply, is easily accessible at any time. The IQAN module and standalone controller instruction books show how to connect an emergency stop.

Connecting of supply voltage, IQAN module

The supply voltage, should be within the operating range, see Appendix A, on page 18. Connect the supply voltage to POWER +5Vdc, pin C1:5, C1:7 and C2:4. The regulated 5Vdc is supplied from an IQAN module's +VREF. The ground connection is made from GND pin C1:1, C1:3 and C2:1 to the IQAN module's -VREF.

EXAMPLE

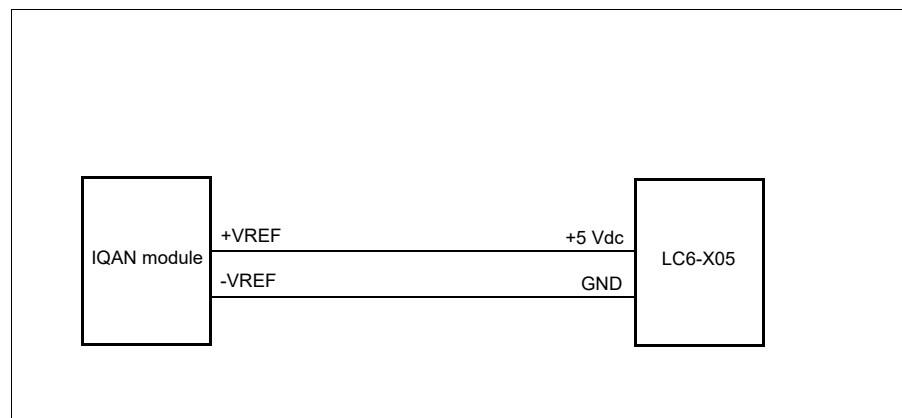

Connecting an IQAN-LC6-X05 to IQAN module.



NOTICE

Maximum load for the *VREF* position is different between types of IQAN modules. Refer to the appropriate instruction book.



NOTICE

Do not exceed power supply limits for the joystick base and handle!

Reversed polarity, or supply voltage different from recommended operating conditions will seriously damage the unit, see Appendix A, on page 18.

Output signals

Primary and secondary outputs

The IQAN-LC6-X05 has two sensors for each axis that have their output signals mirrored. The two outputs allow the user to set up controller logic that monitors the integrity of the two joystick signals to ensure that the joystick is operating properly. It is possible to use only one signal but it is recommended to use both.

Connecting of IQAN-LC6-X05 base outputs

When you connect the IQAN-LC6-X05 joystick to a module or standalone controller, you should use both primary and secondary signals from the joystick. The primary signal for the axis is connected to a VIN, *voltage input* and the secondary signal for the axis is connected to a separate VIN on the controller module.

Connect each primary axis 10%-90% Vs output signal to VIN, and connect the corresponding secondary axis 90%-10% Vs output signal to another VIN.

EXAMPLE

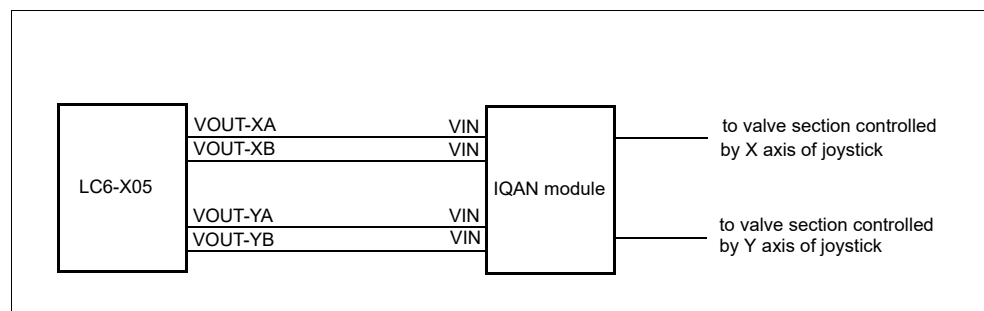

Connecting an IQAN-LC6-X05 to a module.



WARNING

The previous example is presented with limited information to explain the use of primary and secondary signals from the IQAN-LC6-X05. Safety considerations such as the use of an 'operator present' switch to enable outputs etc. are always recommended.

Connecting of -H1 handle outputs

When you connect the IQAN-LC6-X05 joystick handle functions to a module or standalone controller you may have proportional outputs from rocker and knob. You should use both primary and secondary signals from the rocker or knob. The primary signal for the axis is connected to a VIN, *voltage input* and the secondary signal for the axis, if used, is connected to a separate VIN on the controller module.

Connect each primary output 10%-90% Vs output signal to VIN, and optionally connect the corresponding secondary output 90%-10% Vs output signal to another VIN.

EXAMPLE

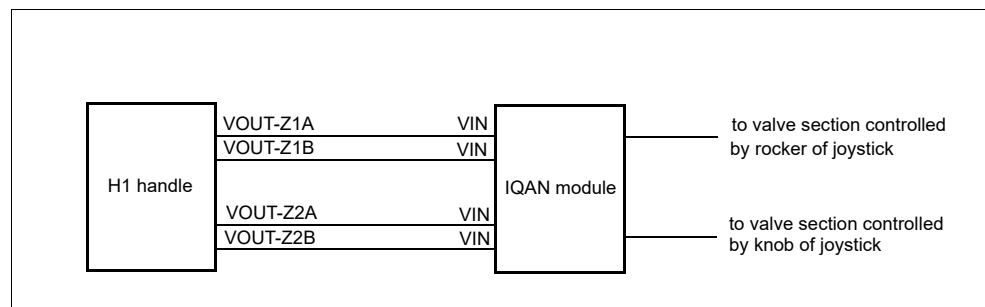

Connecting -H1 rocker and knob outputs to a module.



WARNING

The previous example is presented with limited information to explain the use of primary and secondary signals from the -H1 handle rocker and knob. Safety considerations such as the use of an 'operator present' switch to enable outputs etc. are always recommended.

LC6-H1 handle loss of ground

When using only one of the two possible axis on the -H1 handle, either rocker or knob, the primary signal from the axis not in use must be pulled to ground through a 10k-50 k ohm resistor for safety reasons. If this is not done the connected output will have a unintentional activation if the ground connection to the handle is lost

Connect the primary output pin from the unused axis, through a resistor, to ground.

EXAMPLE

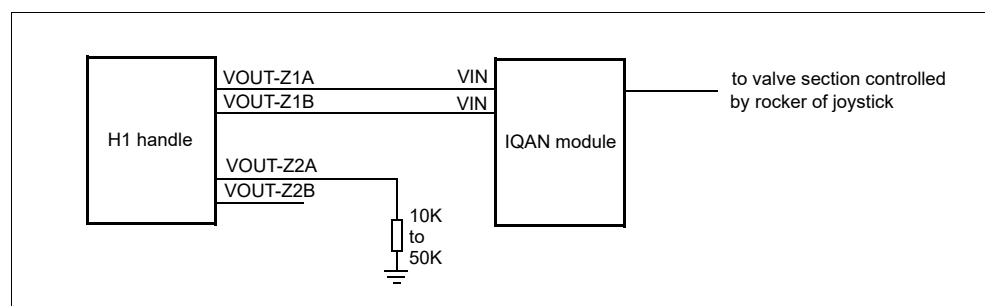

Grounding one of the signals from an unused axis.



WARNING

Possible unintentional activation of the connected axis if the ground connection is lost!

If the supply ground is disconnected from the handle sensors, the output from the connected axis will be around 3.6 V if unused output is not grounded.

Handle considerations

Recommended handle specification

The IQAN-LC6-X05 will accept OEM specified handles. These handles will need to be adapted to mount on the joystick stem. The maximum weight of any handle fitted to the IQAN-LC6-X05 should not exceed 85g. The center of gravity (COG) of the handle shall not be more than 57mm above the flange mounting surface. This recommendation results in a handle that generates a maximum moment of 0,05 Nm with a maximum tilt of 20° of the joystick base. The following formula is used to determine the lever moment force. distance (0.057m) x weight (0,085kg) x constant (9.81g) = force (0,047Nm).



WARNING

Risk of injury! Exceeding the recommended handle specifications could cause unintended movement of the joystick.

Environmental specification

Any handle used with the IQAN-LC6-X05 should be a sealed type that is rated IP65-IP67 for outdoor use. Additionally, the joystick must always have a bellow installed to ensure that it will meet the environmental specification for sealing above the flange. When using a handle from a different manufacturer than Parker, be sure to include a suitable bellow made of a material that is able to withstand the stresses of outdoor use in mobile hydraulic machinery.



NOTICE

Failure to use a properly fitted bellow of the correct material will cause the unit to not meet its environmental specification and may result in damage to the IQAN-LC6-X05 joystick.

Appendix A

IQAN-LC6-X05 Technical Overview

IQAN-LC6-X05, base and -H1 handle

Absolute Maximum Ratings^a

Ambient temperature	-40 to 70 °C
Storage temperature	-40 to 85 °C
Maximum overvoltage on any pin	10V for max 60 minutes
External magnetic field	15 mT

a. The "Absolute Maximum Ratings" table lists the maximum limits to which the device can be subjected without damage. **This doesn't imply that the device will function at these extreme conditions**, only that, when these conditions are removed and the device operated within the "Recommended Operating Conditions", it will still be functional and its useful life won't have been shortened.

Environmental ratings

T_A = -40 to 85 °C (unless otherwise specified)

Climate environment Enclosure, water & dust protection Salt mist Damp heat cyclic Damp heat steady state Heat, operation Heat, storage Cold Change of temperature	IEC 60529:2001, IP65 (with sealed handle and bellow) IEC 60068-2-52:1996 Kb, 72 h IEC 60068-2-30:1985 Db, +55°C, 95% RH, 6 cycles IEC 60068-2-78:2001, +40°C, 93% RH, 21 days IEC 60068-2-2:1993-01 Bb, +85°C, 72 hours IEC 60068-2-2:1993-01 Bb, +100°C, 72 hours IEC 60068-2-1:1993-02 Ab, -40°C, 16 hours IEC 60068-2-14:1984 Nb, - 30°C to +85°C, 100 x 4 hours
Mechanical environment Random vibration Bump	IEC 60068-2-64:2008 Fh, 15 - 1000 Hz, 11.6 Grms, 3 x 10 h IEC 60068-2-29:1987 Eb, 40 g, 6 ms, 1000 * 6 dir
EMC Radiated emission Conducted susceptibility Radiated susceptibility Conducted transients susceptibility ESD, Operation ESD, Handling	ISO 13766/ISO 14982 ISO 11452-4:2005, 1 - 200 MHz, 1 kHz, 80% AM, 100 mA ISO 11452-2:2004, 200-2000 MHz, 1kHz, 80% AM, 100 V/m ISO 7637-3:2007, Level 3 ISO 10605:2001, 8 kV (contact), 25 kV (air) ISO 10605:2001, 4 kV (contact)

Base - Electrical characteristics

Voltage supply on Vs	4.5 to 5.5 V
Current supply, VS = 5V	max. 45 mA, typ. 34 mA (base only)
Number of VOUT	4, antivalent signals
VOUT minimum position, VS = 5V	500 mV \pm 100 mV (over expected life)
VOUT centre position, VS = 5V	2500 mV \pm 220 mV (over expected life)
VOUT maximum position, VS = 5V	4500 mV \pm 100 mV (over expected life)
VOUT maximum linearity error	200 mV
VOUT antivalent tracking	200 mV
VOUT resolution	12 bits = 1.22 mV
Response time	4 ms
Minimum resistive load	1 kohm
Maximum resistive load	24 kohm
Maximum capacitive load	100 nF
Maximum continuous voltage	5.5 V
Protection	SCG
MTTFd	VOUT-XA 5723 [y] VOUT-XB 5723 [y] VOUT-YA 5723 [y] VOUT-YB 5723 [y]

Base - Mechanical characteristics

Weight	.24 kg (with -H1R1K1 handle)
Angle of movement	\pm 20°
Spring option nn (medium)	
Deflection moment, neutral	0.10 Nm
Deflection moment, fully activated	0.16 Nm
Mechanical strength XY, working	10 Nm
Mechanical strength XY, one time	15 Nm
Mechanical strength twist, working	2 Nm
Mechanical strength twist, one time	5 Nm
Expected life	5x10 ⁶ full cycles (One cycle: Center pos. to full +direction and back, center pos. to full - direction and back)

Option R1 (Rocker)

Voltage supply on Vs	4.5 to 5.5 V
Current supply, VS = 5V	max. 23 mA, typ. 17 mA
Number of VOUT	2, antivalent signals
VOUT minimum position, VS = 5V	500 mV \pm 100 mV (over expected life)
VOUT centre position, VS = 5V	2500 mV \pm 220 mV (over expected life)
VOUT maximum position, VS = 5V	4500 mV \pm 100 mV (over expected life)
VOUT maximum linearity error	200 mV
VOUT antivalent tracking	200 mV
VOUT resolution	12 bits = 1.22 mV
Response time	4 ms
Minimum resistive load	1 kohm
Maximum capacitive load	100 nF
Maximum continuous voltage	5.5 V
Current supply, VS = 5V	max. 23 mA, typ. 17 mA
Protection	SCG
MTTFd	VOUT-Z1A 4986 [y] VOUT-Z1B 4986 [y]
Angle of movement	\pm 20°
Deflection moment, neutral	0.008 Nm
Deflection moment, fully activated	0.012 Nm
Expected life	5x10 ⁶ full cycles (One cycle: Center pos. to full +direction and back, center pos. to full - direction and back)

Option K1 (Ring)

Voltage supply on Vs	4.5 to 5.5 V
Current supply, VS = 5V	max. 23 mA, typ. 17 mA
Number of VOUT	2, antivalent signals
VOUT minimum position, VS = 5V	500 mV \pm 100 mV (over expected life)
VOUT centre position, VS = 5V	2500 mV \pm 220 mV (over expected life)
VOUT maximum position, VS = 5V	4500 mV \pm 100 mV (over expected life)
VOUT maximum linearity error	200 mV
VOUT antivalent tracking	200 mV
VOUT resolution	12 bits = 1.22 mV
Response time	4 ms
Minimum resistive load	1 kohm
Maximum capacitive load	100 nF
Maximum continuous voltage	5.5 V
Current supply, VS = 5V	max. 23 mA, typ. 17 mA
Protection	SCG
MTTFd	VOUT-Z2A 4986 [y] VOUT-Z2B 4986 [y]
Angle of movement	\pm 20°
Deflection moment, neutral	0.005 Nm
Deflection moment, fully activated	0.0075 Nm
Expected life	5x10 ⁶ full cycles (One cycle: Center pos. to full +direction and back, center pos. to full - direction and back)

Appendix B

Dimensioning of the IQAN-LC6-X05

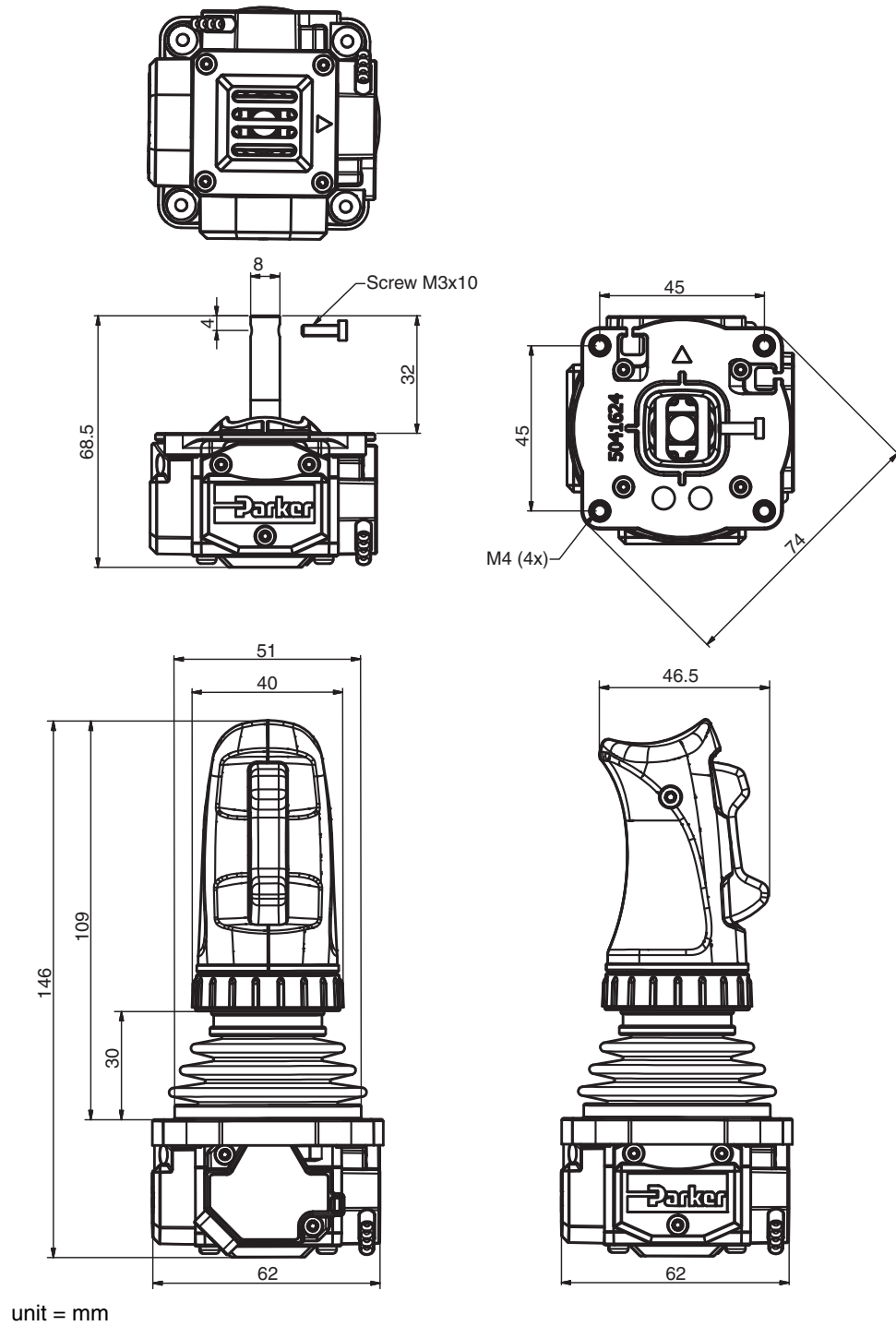

For latest information visit our website www.iqan.com

Information in this instructionbook is subject to change without notice

Parker Hannifin
Mobile Systems Division
SE-435 35 Mölnlycke
Sweden
Tel +46 31 750 44 00
Fax +46 31 750 44 21
www.parker.com

Parker Hannifin
Electronic Controls Division
1651 N. Main Street
Morton, IL 61550
USA
Tel +1 309 263 7788
Fax +1 309 266 6674

Publ no MSG17-8409-IB/UK
Edition 2018-09-05

